

THE *General Radio* EXPERIMENTER

VOLUME XXVIII No. 12

MAY, 1954

Copyright, 1954, General Radio Company, Cambridge, Mass., U. S. A.

ELECTRONIC APPARATUS FOR SCIENCE AND INDUSTRY

A NEW SENSITIVE, HIGH-FREQUENCY, GENERAL-PURPOSE DETECTOR

Deliveries Are Good

Delivery of this new TYPE 1216-A Unit I-F Amplifier is from stock.

Speed and accuracy of order handling has always been a particular GR aim. Now, with adequate stocks of most products, about 85% of orders are shipped within less than 48 hours from their receipt. Technical or commercial questions may hold up an order, but only for long enough to assure a correct and satisfactory shipment.

● **ONE OF THE BASIC TOOLS** necessary for carrying out development work at any frequency is a sensitive detector. At low frequencies, vacuum-tube amplifiers and commercially available communications receivers are usually satisfactory for this purpose.

For operating frequencies above some 50 megacycles, however, very few receivers are available, and the problem of obtaining a satisfactory detector is a difficult one to solve. One method of extending the range of a communications receiver is to add a converter ahead of it to hetero-

dyne the high frequency signals down to frequencies within the range of the receiver. A wide-band converter of this type can be made up of a TYPE 874-MR Mixer Rectifier and one of the General Radio Unit Oscillators as shown in the block diagram in Figure 2. Although a communications receiver in this arrangement can be made to perform satis-

Figure 1. Panel view of the Type 1216-A Unit I-F Amplifier.



IET LABS, INC in the GenRad tradition

534 Main Street, Westbury, NY 11590

TEL: (516) 334-5959 • (800) 899-8438 • FAX: (516) 334-5988

www.ietlabs.com

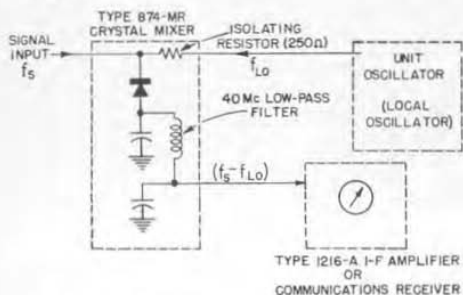

Figure 2. Block diagram of a heterodyne detector system for high frequencies.

factorily at the lower frequencies, and has good sensitivity and excellent shielding, it has two important limitations: (1) its bandwidth is so narrow that slight changes in the frequency of either the signal or the oscillator cause serious detuning, and (2) it is large and unwieldy compared to other elements in the system.

To overcome these limitations a new instrument, the TYPE 1216-A Unit I-F Amplifier, has been designed especially for use in the detector system of Figure 2. This small high-gain, wide-band, 30-Mc amplifier is shown in Figure 1 and, in conjunction with the TYPE

874-MR Mixer Rectifier and a Unit Oscillator, as a unit of a DNT Detector Assembly in Figure 3. With this combination, signals from 25 to 5000 megacycles can be detected, depending upon the range of the Unit Oscillator used.

The TYPE 1216-A Unit I-F Amplifier, latest of General Radio's extensive line of Unit Instruments, has many features which make it well adapted for use in the general-purpose detector circuit. Some of these features are:

1. High sensitivity.
2. Broad bandwidth with good selectivity.
3. Small physical size.
4. Light weight.
5. Built-in precision attenuator.
6. Meter has both a linear relative-voltage scale and a db scale.
7. Automatic volume control.
8. Excellent shielding.
9. Provision for measuring rectified mixer current.
10. Cathode-follower output amplifier for demodulated signal.
11. Two separate internal power supplies, one for operating a Unit Oscillator.

Figure 3. View of the DNT-3 Detector Assembly, utilizing General Radio coaxial elements and Unit Instruments.



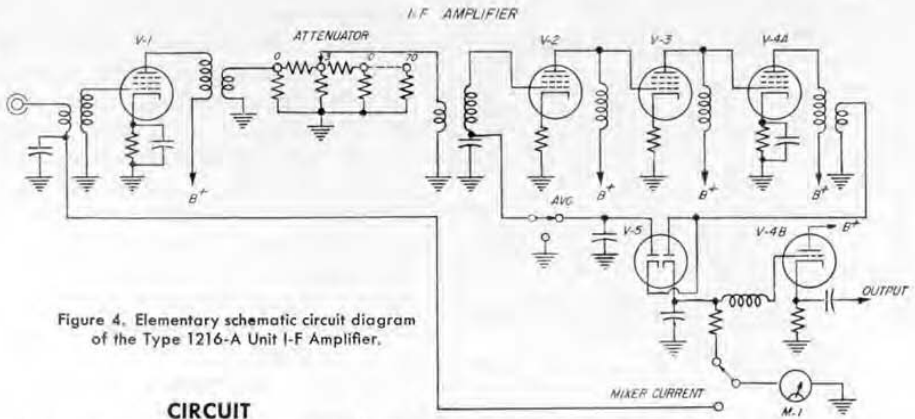

Figure 4. Elementary schematic circuit diagram of the Type 1216-A Unit I-F Amplifier.

CIRCUIT

A simplified circuit diagram of the amplifier is shown in Figure 4. There are four i-f amplifier stages, followed by a diode detector and a cathode-follower low-frequency amplifier.

Amplifier

A tuned step-up transformer is used at the input to obtain a better impedance match between a crystal mixer and the grid of the first tube. A step-down transformer is used between the output circuit of the first stage and the input to the attenuator in order to minimize the mismatch loss caused by the use of a 50-ohm attenuator. A step-up transformer is provided at the output of the attenuator for the same reason. These tuned transformers have very wide bandwidths in order to keep negligibly small the attenuator error at the extremes of the pass band.

The over-all bandwidth of the amplifier between half-power points is about 0.7 Mc, and a high degree of selectivity to frequencies outside of the pass band is obtained. The over-all frequency response curve of a typical instrument is shown in Figure 5.

Figure 5. Over-all selectivity curve of a typical Type 1216-A Unit I-F Amplifier.

The 100-db gain makes possible high sensitivity. A 30-Mc input of less than $2\mu\text{v}$ is required for a meter deflection of 1% over the residual noise, and an input of less than $50\mu\text{v}$ produces a full-scale meter deflection when the avc is not used.

Attenuator

The built-in attenuator is located between the first and second stages and uses carbon-film resistors mounted on a shielded wafer switch. The 50-ohm im-

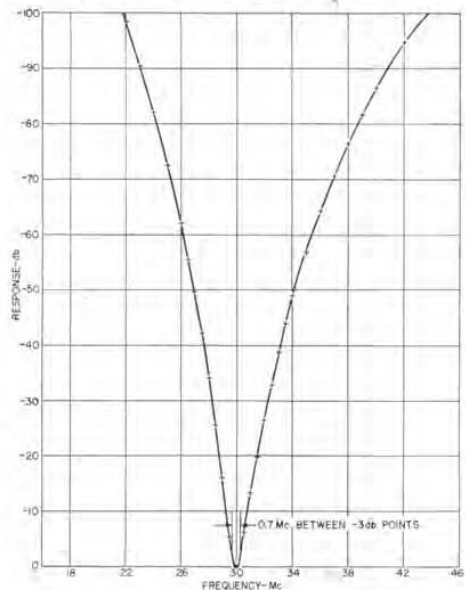

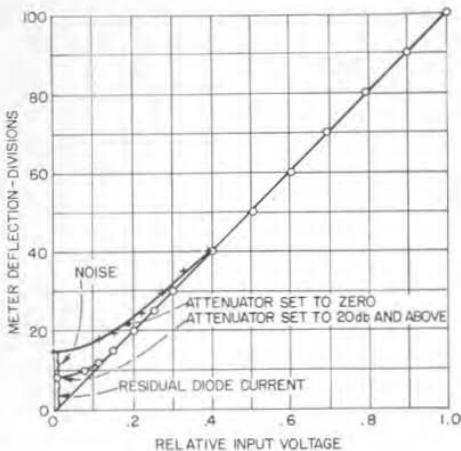

Figure 6. Curve showing linearity of amplitude response.

pedance level minimizes errors caused by residual capacitance and inductance. Steps of 0, 3, 10, 20, 30, 40, 50, 60, and 70 db are included. A straight-through connection is made between the input and output for the zero db positions, and individual π -type sections are switched into the circuit for the 3- and 10-db steps. At all higher steps a ladder-type network is used. An accuracy of $\pm(1\% + 0.3 \text{ db})$ in the indicated attenuation is obtained. The attenuator can be seen at the left of Figure 7.

Diode Detectors

The output of the 30-Mc amplifier is rectified by a double-diode detector. The d-c output from one diode is applied to the meter and is a measure of the signal level. In order to obtain a high degree of linearity, the diode is operated at a high voltage level; 6 volts are required for a full-scale meter deflection. Figure 6 shows the amplitude response of a typical unit. The db scale of the meter permits interpolation between attenuator steps.

The meter can be switched to indicate the rectified current produced by the action of the local-oscillator voltage on the mixer. A full-scale reading corresponds to a voltage of about two volts applied across the mixer crystal.

The a-c output of the same diode, which follows the modulation envelope of the 30-Mc signal, is amplified and brought out on binding posts on the panel. The bandwidth of the low-frequency circuits is about 0.4 Mc and the output impedance is 600 ohms. The maximum open-circuit output voltage is two volts.

The second diode is used to supply an a-v-c voltage which can be applied to the second amplifier stage. A typical a-v-c characteristic is shown in Figure 8.

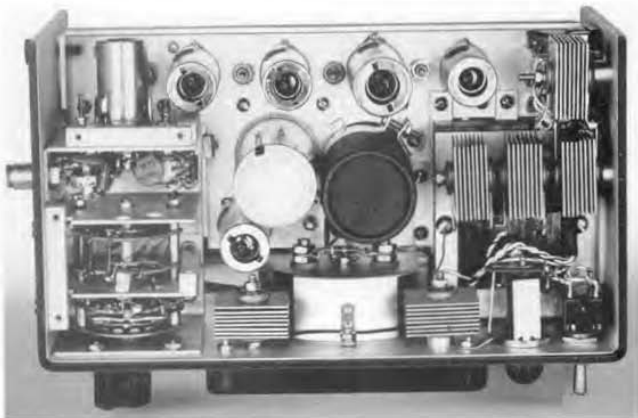

Figure 7. View of chassis from top with shields removed. The attenuator and first amplifier stage are in the shielded compartment at the left.



Power Supply

The two internal power supplies are provided to reduce the number of units involved in a detector assembly, thereby improving portability and simplifying interconnection. Regulation of the screen voltages on the i-f amplifier tubes is provided by means of a TYPE OB2 Regulator Tube.

As shown in Figures 7 and 9, the internal parts of the unit are individually shielded and numerous filters are provided for isolation.

The complete assembly is housed in

SPECIFICATIONS

Center Frequency: 30 Mc.

Bandwidth: 0.7 Mc at 3 db down; 9.5 Mc at 60 db down.

Sensitivity: Less than 2 μ volt input from a 400-ohm source required for a 1% meter deflection (above noise). Less than 50 μ volt input from a 400-ohm source required for full-scale meter deflection. Input voltages referred to are open-circuit source voltages.

Attenuator Range: 0 to 70 db in 10-db steps. A single 3-db step is also provided.

Accuracy of Attenuator: $\pm(0.3 \text{ db} + 1\%$ of indicated attenuation).

Bandwidth of Low-Frequency Output Circuits: 0.4 Mc. **Output Impedance (Low-Frequency Circuits):** 600 ohms.

Maximum Output Voltage: 2 volts open circuit.

Terminals: Input — TYPE S74 Connector on end of 2-foot cable.

Output — Binding posts on $\frac{3}{4}$ -inch spacing.

Supplementary Power Supply Output: 300 volts dc at 40 ma; 6.3 volts ac at 1 a.

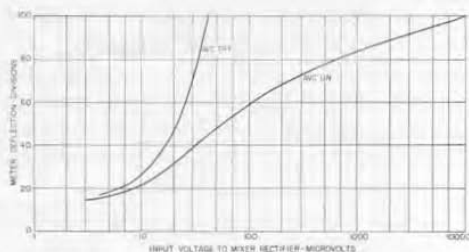

Figure 8. A-V-C characteristic of a typical instrument.

a standard General Radio Unit Instrument cabinet, with over-all dimensions of 10 x 5 $\frac{5}{8}$ x 6 $\frac{3}{8}$ inches.

Power Supply: 105-125 or 210-250 volts, 50 to 60 cycles. Power input with no load on supplementary power supply — 26 watts at 115 volts. Power input with TYPE 1209-A Oscillator connected to supplementary power supply — 40 watts at 115 volts.

Tubes: Supplied with instrument:

1 — 6AK5 1 — 6AL5
1 — 6U8 1 — OB2
2 — 6CB6

Accessories Supplied: Spare fuses; power cord is integral with the unit.

Other Accessories Available: TYPE S74-MR Mixer Rectifier. Unit oscillator of appropriate frequency range to provide heterodyning signal. TYPE 1208-A, 1209-A, or 1215-A is recommended.

Mounting: Black-crackle finish aluminum panel and sides. Aluminum cover finished in clear lacquer.

Dimensions: (Height) 5 $\frac{5}{8}$ x (width) 10 x (depth) 6 $\frac{3}{8}$ inches, over-all.

Net Weight: 8 $\frac{1}{4}$ pounds.

Type

1216-A

Unit I-F Amplifier*

Code Word

AMONG

Price

\$365.00

*U. S. Patents Nos. 2,125,816 and 2,548,457.

Figure 9. View from below with shields removed. The i-f amplifier section extends along the rear of the chassis and is normally completely enclosed in a shield.

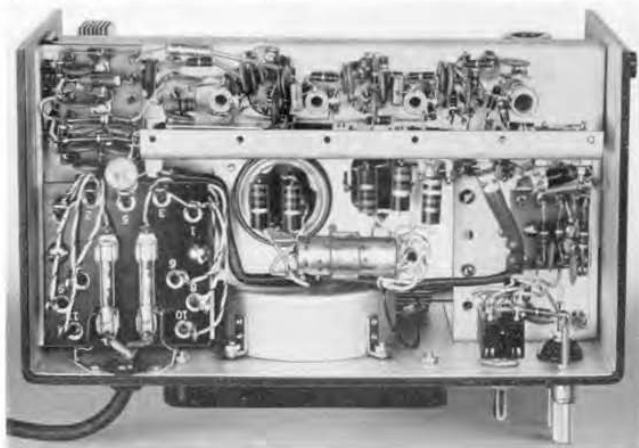



CHARACTERISTICS OF THE TYPE DNT DETECTOR

The Type DNT Detector, made up of the combination of the TYPE 874-MR Mixer Rectifier, the TYPE 1216-A 30-Mc Unit I-F Amplifier, and a Unit Oscillator, has many characteristics that make it a very valuable instrument for laboratory, production, and field work. Some of these characteristics are the following:

1. *Convenience and Small Size.* As shown in Figure 3, the detector is physically small and easily transportable. The built-in power supply for the Unit Oscillator and the built-in means of measuring the rectified crystal current add to the convenience of operation.

2. *Wide Frequency Range.* The range is primarily determined by that of the Unit Oscillator used, with the low-frequency limit of 25 Mc¹ determined by the frequency at which the local oscillator voltage starts to produce a significant residual meter reading, and the high-frequency limit of 5000 Mc arbitrarily set at the point at which the sensitivity tends to drop off rather rapidly. Satisfactory detection can be obtained using either the fundamental or a harmonic of the local-oscillator signal, but with harmonic operation the sensitivity is slightly lower (see Figure 10) and more care must be exercised to insure setting to the proper signal particularly at the higher harmonics. A low-pass filter, such as the TYPE 874-F500 or TYPE 874-F1000, can be used to eliminate harmonic responses. The following frequency ranges can be obtained with General Radio Unit Oscillators operating on the fundamental.

¹ Both the signal itself and its beat with the local oscillator will be present when the signal frequency is near 30 Mc. Since all components depend upon the signal magnitude, however, the presence of what would normally constitute spurious signals is not detrimental to detection of a null or indication of relative signal levels.

Unit Oscillator Type Number	Detector Fundamental Frequency Range
1215-A	25 to 280 Mc
1208-A	35 to 530 Mc
1209-A	220 to 950 Mc

3. *Excellent Shielding.* The high-frequency circuit is confined to the internal parts of the mixer, and a 40-Mc low-pass filter, located between the mixer and the 30-Mc output, prevents r-f signals leaking into the mixer through the i-f amplifier. This is more than adequate to meet the stringent shielding requirements when the detector is used as a null-detector for high-frequency bridges or other null-type devices, as a standing-wave detector for slotted lines, or in attenuation measurements, particularly when a radiating circuit is being measured.

4. *Calibrated 80-db Range.* Relative signal levels at high frequencies can be measured by determining the corresponding 30-megacycle levels as measured by the attenuator and meter in the amplifier. When adequate local-oscillator voltage is applied, the crystal mixer is an accurate linear conversion device over the whole range of the attenuator and meter, and levels differing by as much as 80 db can be measured directly. Figure 10 is a chart showing the variation in conversion efficiency with rectifier mixer current for a typical crystal, and Figure 11 shows the measured over-all error in attenuation for various values of rectified mixer current for a typical detector assembly.

5. *AVC.* The automatic volume control makes it more convenient to balance null-type instruments, as the meter remains on scale over a wide range of input signal levels with no reduction in maximum sensitivity.

6. *Uniform High Sensitivity.* The sensitivity is reasonably constant over wide



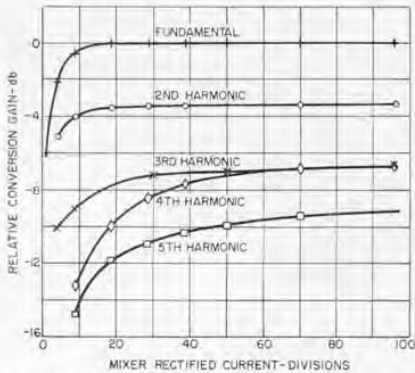

Figure 10. Curves showing relative conversion gain as function of rectified mixer current for the fundamental and harmonics of the local oscillator.

frequency ranges. Figure 12 shows typical variation over the lower part of the frequency range. The impedance of the local-oscillator circuit at the signal frequency appears in series with the 250-ohm isolating resistor in the mixer rectifier, and the combination appears in parallel with the crystal. As the local oscillator impedance at the signal frequency varies from zero to infinity, the effective sensitivity varies by 1.6 db for a 50-ohm signal source. Figure 12 shows such a variation occurring rather rapidly with frequency when a patch cord is connected between the Unit Oscillator and the mixer. When the mixer is connected directly to the Unit Oscillator, the variation occurs much more slowly with frequency as shown.

Note that a signal input voltage of only about 50 microvolts produces a full-scale meter deflection. An r-f input of about $3\mu\text{v}$ is detectable above the noise on the meter in typical units.

At frequencies below 50 Mc, the sensitivity is further affected by the finite input impedance of the 40-Mc low-pass filter, which appears in series with the crystal.

7. *Matching to 50 ohms.* The input impedance of the detector is high compared to 50 ohms, but it can be made to match a 50-ohm line by inserting a TYPE 874-GG 10-DB Pad or a TYPE 874-GF 20-DB Pad between the mixer and the signal input. With the 10-db pad, the VSWR looking into the detector will be less than 1.1 at low frequencies, less than 1.3 at 1000 Mc, and less than 1.5 at 2000 Mc. With the 20-db pad, the input VSWR will be less than 1.05 at low frequencies, less than 1.2 at 1000 Mc, and less than 1.4 at 2000 Mc.

APPLICATIONS OF THE DETECTOR

1. Detector for Null-Type Measuring Devices.

The TYPE DNT Detector, consisting of a TYPE 874-MR Mixer Rectifier, a TYPE 1216-A 30-Mc Unit I-F Amplifier, a Unit Oscillator and accessories, is well suited for use with high-frequency null-type measuring instruments such as the TYPE 1602 U-H-F Admittance Meter.

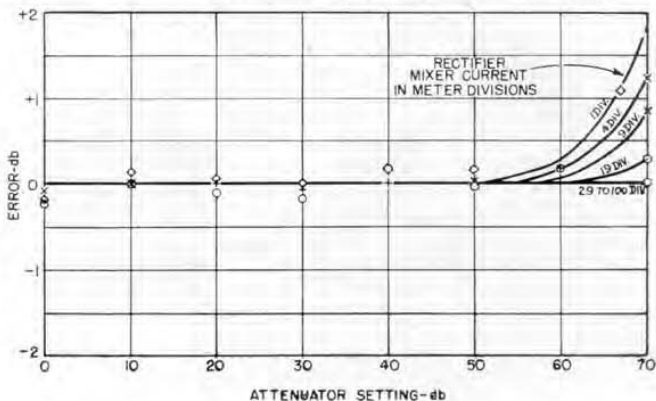

Figure 11. Over-all error in signal-level measurements for a typical Type DNT Detector Assembly as a function of attenuator setting for various values of rectified mixer current. Full-scale meter deflection was used in determining these data.

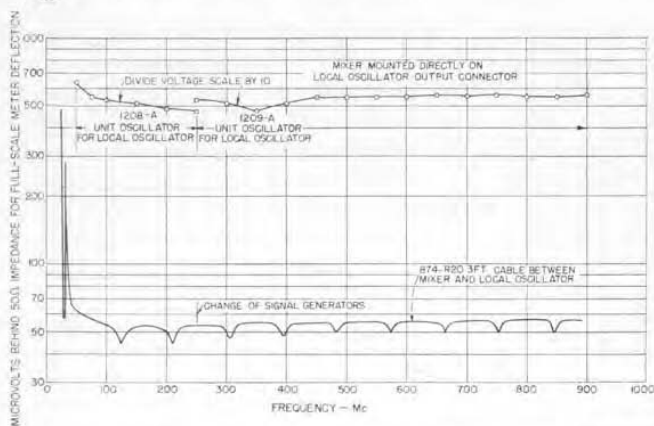

Figure 12. Sensitivity vs. frequency for a typical Type DNT Detector Assembly. Note that about 50 microvolts are required for full-scale deflection. For a 1% meter deflection, above noise, only 3 microvolts are required.

The detector is compact, well shielded, and very sensitive, has a good ave, and covers a wide frequency range. Figure 13 shows a typical setup for the measurement of the VSWR of a coaxial switch.

2. Detector for Voltage-Ratio-Type Measurements.

The detector is also well suited for application to instruments such as directional couplers, slotted lines, and the admittance meter using voltage ratio methods, since the relative voltage differences can be measured accurately and quickly by means of the step attenuator and calibrated meter. Its high degree of sensitivity, linearity, and harmonic rejection, and its usefulness with c-w signals make the instrument particularly well suited to high VSWR measurements on slotted lines.

3. Insertion-loss and Attenuation Measurements of Filters, Attenuators, and Cables.

The combination of the detector and an additional Unit Oscillator, each fitted with a 10- or 20-db pad to make its impedance approximate 50 ohms, forms a simple setup for measuring the accuracy of attenuators, the attenuation of coaxial cables, and the insertion loss of filters both in the pass and rejection bands. In this type of measurement the substitution method is used. The Unit Oscillator and detector are first connected directly together through the two pads and the attenuator is set to obtain an on-scale meter reading. The circuit is then broken at the junction of the two pads, the circuit under test inserted, and the attenuator adjusted for an on-scale meter read-



Figure 13. The Type DNT Detector Assembly is an excellent detector for use with the Type 1602-B U-H-F Admittance Meter, as shown here in a setup for measuring VSWR of a coaxial switch. The Type 1204-B Unit Variable Power Supply shown below the i-f amplifier is used to energize the solenoid in the coaxial switch.





Figure 14. View of the Type DNT-1 Detector Assembly and a Type 1208-A Unit Oscillator set up for insertion-loss measurements on a 185-megacycle low-pass filter.



ing. The difference in the sums of the attenuator and meter readings is equal to the insertion loss of the sample. Samples having insertion losses as high as 80 db can be measured directly, and up to about 95 db can be measured with the insertion of extra pads. The excellent shielding of the detector makes high-insertion-loss measurements reliable.

The detector can also be used with a signal generator having a calibrated r-f attenuator for insertion-loss measurements. In this case the attenuator in the generator can be used, if desired, rather than the attenuator in the amplifier. With either method, the high sensitivity, excellent shielding, and wide frequency range of the detector contribute greatly to the convenience and reliability of the measurements.

The results of measurements made on the insertion loss of the 185-Mc low-pass filter shown in Figure 14 are presented in Figure 15. The measurements were made by two methods. In one case a Unit Oscillator was used as a source and the loss measured in terms of the attenuator in the Unit I-F Amplifier. In the second method a TYPE 1021-A Signal Generator was used and the measurement made with its calibrated attenuator. It will be noted that the agreement is extremely close.

Figure 15. Results of measurements made with the set-up of Figure 14.

4. Calibration of High-Frequency Attenuators.

The calibration of variable high-frequency attenuators such as those used on signal generators can be easily and rapidly measured over wide frequency ranges by comparison with the built-in 30-Mc attenuator.

5. VSWR and Cross-Talk Measurements in Coaxial Switches.

Measurements of the input VSWR on coaxial switches can be easily made using the admittance meter setup as outlined

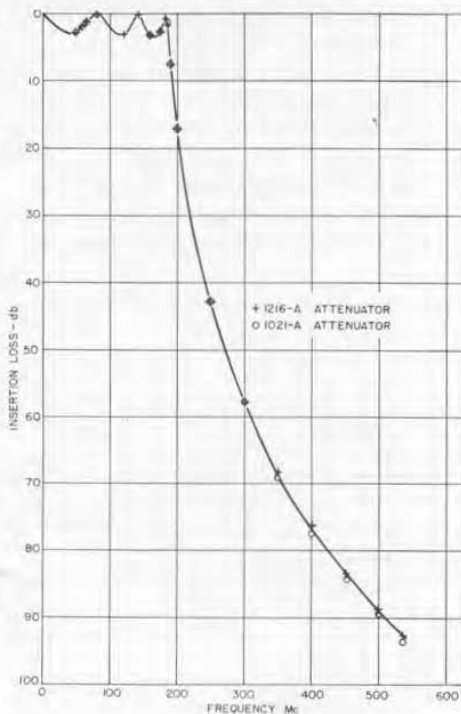

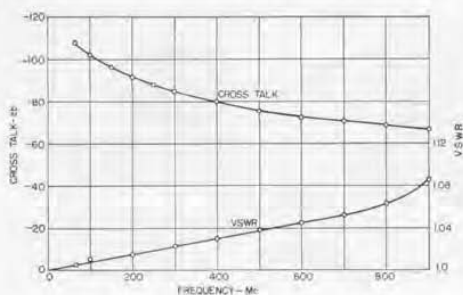

Figure 16. Cross-talk and VSWR characteristics of a coaxial switch as measured with the equipment shown in Figures 13 and 14.

in (1) with the switch terminated in a TYPE 874-WM 50-ohm Termination. Figure 13 shows a typical setup. The same equipment, with two pads substituted for the admittance meter, can be used for cross-talk measurements as outlined in (3) and shown in Figure 14. Results of typical measurements are plotted in Figure 16.

6. General-Purpose, Sensitive, Tuned Voltmeter.

The detector itself can be used to monitor and to measure relative changes in voltage levels at voltages as low as 10 μ v over a wide frequency range. For absolute measurements, the mixer can be calibrated at one reasonably high signal level, additional pads being used,

if necessary, by means of a high-level voltmeter or bolometer power-measuring device such as the TYPE 1651-A Bolometer Bridge.

7. Wave Analysis.

With some limitations the detector can be used as a v-h-f or u-h-f wave analyzer. The limitations arise from (1) the responses obtainable on images and harmonics of the local-oscillator signal and (2) the non-linear crystal characteristic, which generates significant harmonics when the signal level is high. The first limitation can in many cases be overcome by the use of low-pass or band-pass filters. The second limitation places a limit on the minimum measurable harmonic percentage. Figure 17 is a series of curves showing the relative harmonic voltage generated as a function of the fundamental signal voltage level for various local-oscillator excitations.

The TYPE 1216-A Unit I-F Amplifier and the complete Type DNT Detector Assemblies fill an important need in high-frequency measuring systems. Their versatility and adaptability lead to applications in measurement and testing in the laboratory, in the field, and on the production line.

— R. A. SODERMAN

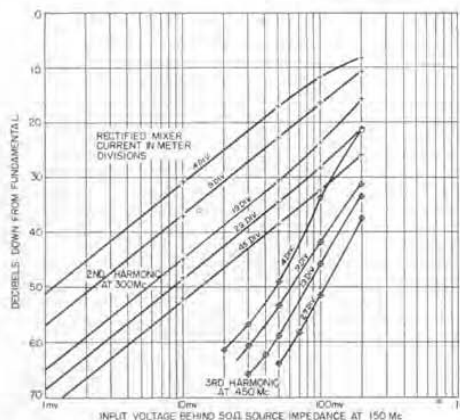

Figure 17. Curves showing the relative amplitudes of harmonic generated in the mixer as a function of fundamental signal voltage level for various local-oscillator excitations.





TYPE DNT DETECTOR ASSEMBLIES

To facilitate ordering auxiliary equipment for use with the TYPE 1216-A Unit I-F Amplifier, complete detector assemblies are available for fundamental operation at frequencies between 25 and 950 megacycles. Higher-frequency oper-

ation is obtainable by using oscillator harmonics. Additional oscillator equipment for fundamental frequencies up to 2,000 megacycles will be announced within the next few months.

TYPE DNT-1 DETECTOR ASSEMBLY

Fundamental range: 35 to 530 Mc.

Consisting of:

1 TYPE 874-MR Mixer Rectifier.
1 TYPE 1216-A Unit I-F Amplifier.
1 TYPE 874-F500 L-P Filter.

1 TYPE 874-GG 10-db Pad.
1 TYPE 874-EL 90° Ell.
1 TYPE 1208-A Unit Oscillator.

<i>Type</i>	<i>Code Word</i>	<i>Price</i>
DNT-1 Detector Assembly.....	NALTO	\$628.00

TYPE DNT-2 DETECTOR ASSEMBLY

Fundamental range: 25 to 280 Mc.

Consisting of the same components as listed above with the exception of the Unit Oscillator, which in this assembly is a TYPE 1215-A.

<i>Type</i>	<i>Code Word</i>	<i>Price</i>
DNT-2 Detector Assembly.....	NERVO	\$628.00

TYPE DNT-3 DETECTOR ASSEMBLY

Fundamental range: 220 to 950 Mc.

Similar to above assemblies but with TYPE 1209-A Unit Oscillator and TYPE 874-F1000 Low-Pass Filter.

<i>Type</i>	<i>Code Word</i>	<i>Price</i>
DNT-3 Detector Assembly.....	NULLO	\$667.00

ACCESSORIES—CONNECTORS, ADAPTORS

All General Radio high-frequency instruments are equipped with TYPE 874 Coaxial Connectors, a universal type, any two of which plug directly together.

These connectors are designed specifically for use in measuring equipment and have excellent electrical characteristics.

A sufficient number of patch cords are supplied with General Radio Unit Oscillators, the TYPE 874-LB Slotted Line, and the TYPE 1602-B U-H-F Admittance Meter to take care of all connections to the Type DNT Detector Assemblies. When the detectors are used with other





equipment, patch cords and, if necessary, adaptors should be ordered.

The TYPE 874-MR Mixer Rectifier will plug directly into any signal source equipped with a TYPE 874 Coaxial Connector. If the mixer is to be used at a distance from the source, one or more TYPE 874-R20 Flexible Lines (3-foot patch cords) will be needed. A flexible line is included with the Unit Oscillator so that it can be connected to the mixer. Similarly, a cord with TYPE 874 Coaxial

Connector is attached to the i-f amplifier to plug into the mixer.

When connections are to be made to systems using other types of coaxial connectors, TYPE 874-Q Coaxial Adaptors should be used. These are available in both plug and jack models for the following types: N, C, BNC, HN, and UHF, as well as 1 $\frac{3}{8}$ " and 3 $\frac{1}{8}$ ", 51.5-ohm rigid line, and 3 $\frac{1}{8}$ ", 50-ohm rigid line. Most of these were described in the *Experimenter* for October, 1952.

PATCH CORD

Type		Code Word	Price
874-R20	3-foot Flexible Line.....	COAXHATTER	\$6.00

ADAPTORS

Type No.	Elements Used in Adaptor	Code Word	Price
874-QNP	Type 874 and Type N Plug.....	COAXNUTTER	\$4.50
874-QNJ	Type 874 and Type N Jack.....	COAXNAGGER	3.75
874-QBP	Type 874 and Type BNC Plug.....	COAXBUNNER	4.75
874-QBJ	Type 874 and Type BNC Jack.....	COAXBIGGER	4.75
874-QCP	Type 874 and Type C Plug.....	COAXCUFFER	6.25
874-QCJ	Type 874 and Type C Jack.....	COAXCOGGER	4.75
874-QHP	Type 874 and Type HN Plug.....	COAXHANGER	6.50
874-QHJ	Type 874 and Type HN Jack.....	COAXHAWSER	6.50
874-QUP	Type 874 and Type UHF Plug.....	COAXYUPPER	4.25
874-QUJ	Type 874 and Type UHF Jack.....	COAXYUNDER	4.00
874-QV3	Adaptor to V-H-F 3 $\frac{1}{8}$ " rigid line (51.5 ohms).....	COAXYWAGER	87.00
874-QU3	Adaptor to U-H-F 3 $\frac{1}{8}$ " rigid line (50.0 ohms).....	COAXYULTRA	87.00
874-QV2A	Adaptor to V-H-F 1 $\frac{3}{8}$ " rigid line (51.5 ohms).....	COAXYVERRA	46.00

TYPE 874 Coaxial Connectors are manufactured and sold under U. S. Patents 2,125,816 and 2,548,457.

GENERAL RADIO COMPANY

SINCE 1915—MANUFACTURERS OF ELECTRONIC APPARATUS
FOR SCIENCE AND INDUSTRY

275 MASSACHUSETTS AVENUE
CAMBRIDGE 39 MASSACHUSETTS
TELEPHONE: TRowbridge 6-4400

BRANCH ENGINEERING OFFICES

NEW YORK 6, NEW YORK
80 WEST STREET
TEL.—WOrth 4-2722

LOS ANGELES 38, CALIFORNIA
1000 NORTH SEWARD STREET
TEL.—HOLlywood 9-6201

CHICAGO 5, ILLINOIS
920 SOUTH MICHIGAN AVENUE
TEL.—WABash 2-3820

REPAIR SERVICES

WEST COAST
WESTERN INSTRUMENT CO.
826 NORTH VICTORY BOULEVARD
BURBANK, CALIFORNIA
TEL.—VICTORIA 9-3013

CANADA
BAYL ENGINEERING, LTD.
FIRST STREET
AJAX, ONTARIO
TEL.—Toronto EMpire 8-6886

PRINTED
IN
U.S.A.

