

the GENERAL RADIO Experimenter



© 1956 • GENERAL RADIO Company, Cambridge, Mass., U. S. A.
Since 1915 - Manufacturers of Electronic Apparatus for Science and Industry

VOLUME 31 No. 4

SEPTEMBER, 1956

NEW TELEVISION TRANSMITTER MONITOR

A Major Advance in Station Instrumentation

<i>Also</i> IN THIS ISSUE	Page
NEW TYPE 1800-B VACUUM-TUBE VOLTMETER.....	10

Monitoring equipment for radio and television broadcasting stations must meet or exceed FCC requirements, but reliability and easy maintenance are equally important. Beyond this, the

well-designed and properly used monitor can function as a general test instrument for transmitter operations and maintenance, and these test facilities should be easily available and convenient to use. Finally, obsolescence must be considered and the monitor should be designed not merely to meet today's minimum requirements of accuracy and dependability, but to anticipate those of tomorrow.

Figure 1. Panel view of the Type 1184-A Television Transmitter Monitor

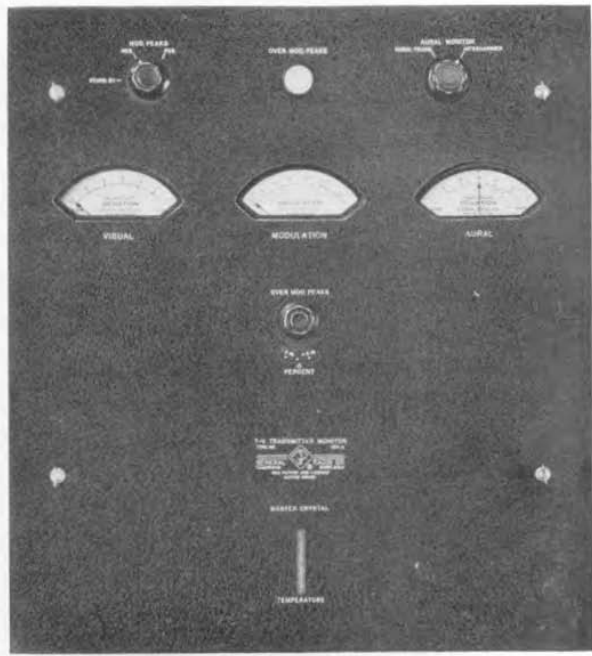

IET LABS, INC in the GenRad tradition
534 Main Street, Westbury, NY 11590

www.ietlabs.com
TEL: (516) 334-5959 • (800) 899-8438 • FAX: (516) 334-5988



The General Radio Company has been concerned with instrumentation for the broadcasting station for thirty years, which provides a fund of field experience unmatched in the industry. General Radio monitors are used by twice as many AM broadcasting and TV stations as all other makes combined.

The design of the new General Radio TYPE 1184-A Television Transmitter Monitor is based upon the field experience with its predecessors and incorporates many features specifically requested by transmitter engineers.

This new instrument is more than a monitor. It provides for many operational tests that will speed and improve adjustment, maintenance, and troubleshooting in both aural and visual transmitter circuits. Continuous audible monitoring against loss of either carrier, and continuous meter monitoring of FM noise on the visual carrier, are typical of the additional functions provided in this new instrument.

It provides maximum protection against obsolescence.

The TYPE 1184-A Monitor is designed beyond mere legal minimum requirements for today's use. Thus protected

against early obsolescence, this new instrument promises *long-term* value that far outweighs initial cost considerations.

It is easy to keep in operation. The TYPE 1184-A Monitor expresses a wholly new concept in mechanical design that gives convenience never before attained in an instrument of this type. Every operation in the installation, use, and maintenance of this new monitor can be handled from the front.

OUTSTANDING FEATURES

Intercarrier Monitoring

The new color TV standards¹ specify tolerances² for both the visual transmitter and intercarrier frequencies, thus requiring monitoring facilities for both. In addition, a complete intercarrier sound-detection system has been included within the monitor. This permits monitoring that simulates actual receiver operation and makes possible the correlation of transmitter performance with receiver listening tests.

Residual F-M Noise on Visual Carrier

No convenient method has hitherto existed for direct measurement of the

residual f-m noise on the visual transmitter carrier. In monochrome operation, noise of this type caused trouble in some types of receivers. With the introduction of color, this condition is more serious because of the danger of possibility of over-modulation or of obtaining saturated colors unless video modulators are prevented from doing so. Adequate limiters properly adjusted. Since a noise burst will appear in carrier-sound-detection receivers as well as either carrier frequency modulation goes to zero, as when the transmitter is modulated to full amplitude in the negative (white) direction, it becomes important to be able to monitor this characteristic. Circuits for this purpose are provided in the monitor.

Construction

In any instrument as complex as this monitor, facility and ease of service are of paramount importance.

All major circuits in the monitor can be checked for proper operation by means of a panel selector switch. All level adjustments are located directly behind a quickly removable panel. The panel itself has only those controls which are necessary to operate the monitor.

By pulling forward on a handle, the monitor can slide the entire monitor out of the relay rack, where it will lock upon metal slides in an extended open position. All tubes, internal components, adjustments, cables, and plug connections are within easy reach. The entire front of the monitor can be serviced in this position. The rear of the monitor is readily accessible as shown in Figure 3.

All adjustments and test points are clearly marked in recognizable characters, and the color code indicates the relative importance of the particular adjustment. Thus, a red-circled control

Figure 2. Front panel removes easily, and entire chassis pulls forward on slides for access to adjustments, test points, and tubes, with monitor operating.



Figure 3. For access to rear or bottom, chassis tilts into this position and is held by latches. Monitor is still operating.





residual f-m noise on the visual transmitter carrier. In monochrome operation, noise of this type caused trouble in some types of receivers. With the introduction of color, this condition is more serious because of the distinct possibility of over-modulation on certain saturated colors unless video modulators are prevented from doing so by adequate limiters properly adjusted. Since a noise burst will appear in inter-carrier-sound-detection receivers whenever either carrier frequency momentarily goes to zero, as when the visual transmitter is modulated to full 100% in the negative (white) direction, it becomes important to be able to monitor this characteristic. Circuits for this purpose are provided in the monitor.

Construction

In any instrument as complex as a monitor, facility and ease of service are of paramount importance.

All major circuits in the monitor can be checked for proper operation by means of a panel selector switch. Input-level adjustments are located directly behind a quickly removable panel plate. The panel itself has only those controls which are necessary to operate the monitor.

By pulling forward on a handle, one can slide the entire monitor out of the relay rack, where it will lock upon two metal slides in an extended *operating* position. All tubes, internal circuit adjustments, cables, and plugs are within easy reach. The entire front shelf of the monitor can be serviced from this position. The rear of the monitor is readily accessible as shown in Figure 3.

All adjustments and test points are clearly marked in recognizable colors and the color code indicates the relative importance of the particular adjustment. Thus, a red-circled control is vital

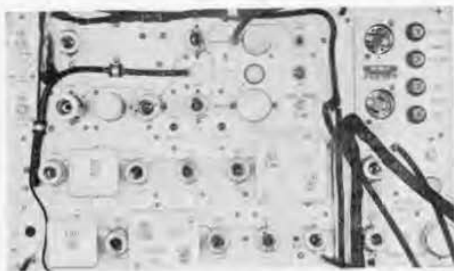

Figure 4. For convenience in maintenance signal paths are indicated by flow lines, adjustments are color coded, and test points are clearly marked.

to the operation and should not be touched without full knowledge of its function. An amber-circled adjustment is intended as a caution sign and implies that some auxiliary measurements may be required in obtaining proper results. A green-circled control is one which may be adjusted readily and does not require any external equipment in establishing its correct setting.

Another assist is given the operator by having "flow lines" or "circuit tracings" outlined upon the top of each shelf. It is thus possible to proceed from a functional block diagram directly to the instrument itself and to follow the circuit progression quite readily. Highly detailed schematic wiring diagrams need only be referred to for isolated troubleshooting in localized spots.

The monitor offers minimum resistance to vertical air flow. This not only prevents overheating of the monitor itself but also does not obstruct the air flow and thus overheat units placed above or below the monitor. Hence the monitor's location in the rack is entirely optional, and a height can be chosen that gives the best visibility.

Precision Temperature-Controlled Oven

A new, precision, temperature-controlled, crystal oven has been designed.





This new unit uses a vacuum flask as the insulating enclosure. Its low thermal losses permit operation with an *average* power of two watts of heat input at normal room temperature. This makes possible a very simple control circuit without relays or the contact-resistance problems usually associated with sensitive thermostats.

BASIC PRINCIPLES

The monitor operates on the same basic principles as its General Radio predecessors.^{2,3,4} It employs a single master-reference frequency, a harmonic of which is heterodyned with both visual- and aural-carrier frequencies to generate two beat frequencies, 4.35 Mc and 150 kc, respectively, which are used in direct monitoring of each carrier separately. This is illustrated in Figure 5. A third beat frequency of 4.5 Mc is also produced by mixing aural- and visual-carrier frequencies and is used in intercarrier monitoring.

Block Diagram

In the center portion of Figure 6 is shown the block diagram of the direct-

monitoring systems. Two additional circuit groups permit the measurement of residual f-m noise on the visual carrier, shown to the left, and provide for intercarrier monitoring, shown to the right.

For direct aural-carrier frequency monitoring, the 150-kc signal (which contains the frequency-modulation components present on the aural carrier) operates an I-F limiter-amplifier, which drives a pulse-counter discriminator. The d-c component of the output of this discriminator is proportional to the average center frequency of the aural-transmitter carrier frequency.

The 4.35-Mc signal is used for direct visual-carrier frequency monitoring. Since this signal is not frequency modulated, a narrow-band frequency meter can be advantageously used, both for maximum sensitivity and to remove unwanted video modulation components. A second heterodyne process converts the 4.35-Mc signal to 1750 cycles. A limiter-amplifier operating at this frequency feeds a pulse-counter discriminator whose d-c output is a measure of the frequency of the visual-transmitter carrier frequency. This dual

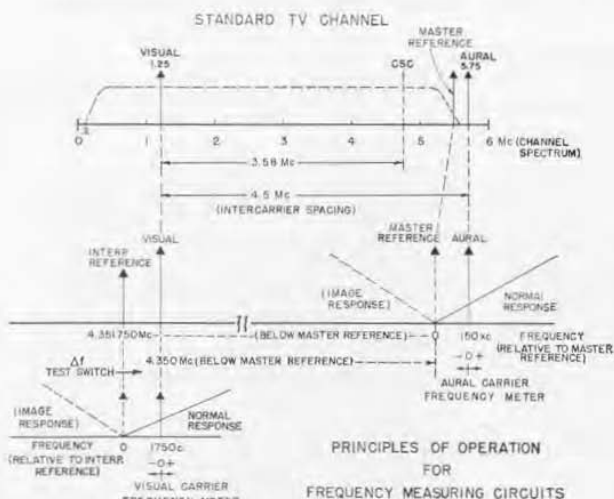

Figure 5. Frequency diagram showing principles of operation.



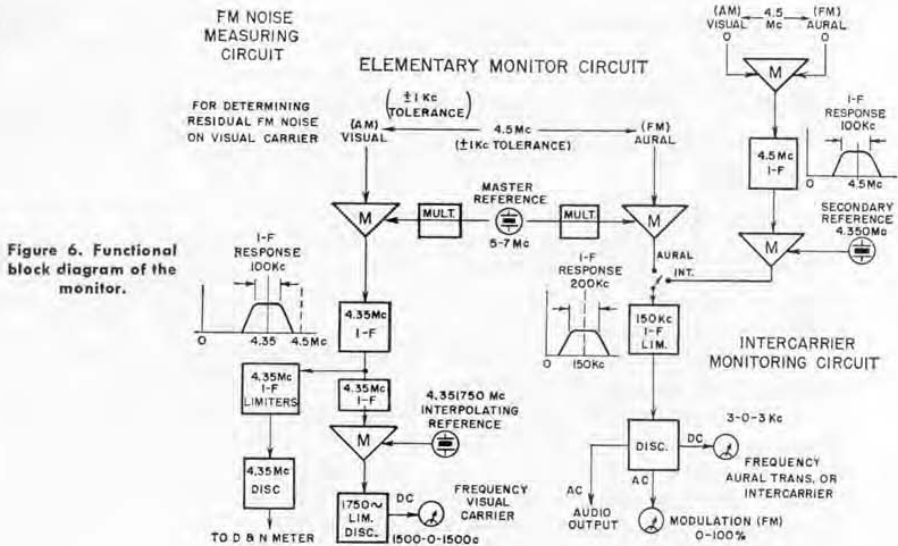

Figure 6. Functional block diagram of the monitor.

conversion step is illustrated at the left of Figure 6.

The 4.35-Mc IF signal is also used to operate a second limiter-amplifier, where the residual amplitude-modulated video components are removed from the signal. It then passes to a tuned-circuit discriminator, the output of which operates an external Distortion and Noise Meter.

The 4.5-Mc intercarrier signal operates a separate I-F limiter-amplifier and is then heterodyned down to 150 kc by means of a secondary reference crystal operating at 4.35 Mc. The resultant 150-kc beat is then available at a panel switch for selectively operating the aural-monitoring circuits from this signal or, alternatively, directly from the 150-kc signal derived directly from the aural transmitter signal.

DESIGN FEATURES

Discriminators

For determining the center frequency of the aural carrier, a meter-discrimina-

tor of high stability is required. For frequency-modulation detection a highly linear discriminator is needed. Heretofore, both of these functions were combined in a single circuit. In the new monitor, two separate discriminators are used, each one optimized for its particular function.

The meter-discriminator is shown in Figure 7. LRC (on the right) comprise a low-Q series circuit operating above the series resonant frequency. The d-c voltage E_1 developed across C-4 is inversely proportional to frequency in the region near 150 kc. The left section, consisting of C-1, the two rectifiers, and C-2, is the conventional pulse-counter circuit, and hence the voltage E_2 is directly proportional to frequency. This gives twice the sensitivity of either circuit acting alone, and, because the d-c meter responds to the differential, small changes in amplitude of the 150-kc driving signal are canceled out at the zero-current position. Since this corresponds to center scale (3-0-3 kc), maxi-

imum accuracy is obtained at the point of maximum use.

The problems involved in this metering circuit can be shown by noting that the meter actually operates over a range of 150 ± 3 kc; hence, the meter scale is only $\pm 2\%$ of the operating frequency. If it must remain stable to, say, one division (i.e., 100 cycles), the over-all circuit stability must be $\pm 100/150,000$ or $\pm 0.067\%$. To achieve this stability requires minute attention to such details as component drift and temperature coefficients. Fortunately, the differential characteristics of the circuit aid in this respect. In this circuit, stability is of paramount importance and every practical means has been used to make it outstandingly good.

An additional advantage of this metering circuit is that no fragile ballast tubes are required to regulate the heaters of d-c amplifier tubes. The rectifiers used are crystal diodes, which have been stabilized against thermal and aging effects by appropriate circuit design.

Audio Discriminator

For frequency-modulation detection, the discriminator must be extremely linear and free of residual noise. Stability is required only to meet the needs of a modulation meter. This discriminator is based upon the well-known pulse-counter types,⁵ as shown in Figure 8. The inherent linearity of these types is well known, but I-F filtering problems

are severe, and sensitivity is usually low. Both of these problems are minimized by a balanced pulse-counter discriminator, which uses transformer output coupling and provides good sensitivity and simple filtering.

Each diode produces, on each half cycle, a current pulse through a resistance, R , as shown in the lower portion of Figure 8. This action is analogous to that of two pulse counters in series. The pulses occur at a uniform rate of 150 kc in the absence of frequency modulation of the 150-kc driving waveform. A d-c component is developed across the resistance R , but no use is made of this, and, obviously, the transformer cannot pass dc. The 150-kc fundamental component is balanced in the transformer, leaving only relatively small-amplitude even harmonics. These are high enough in frequency to be well above the transformer pass band and are therefore highly attenuated.

When the 150-kc input signal is frequency modulated, the current pulses through the resistance R are time modulated, i.e., they occur at a non-uniform rate. The deviation is proportional to the frequency modulation present. The a-c components in the audio range, represented by the time-rate-of-change of these current pulses occurring in the transformer primary, are a measure of the modulation present. These are passed through the transformer and constitute the demodulated audio signals. Only a small amount of

Figure 7. Elementary circuit of balanced discriminator used for center-frequency meter.

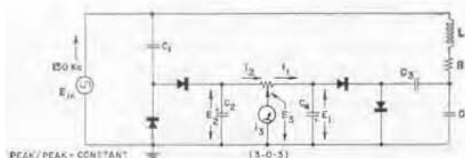
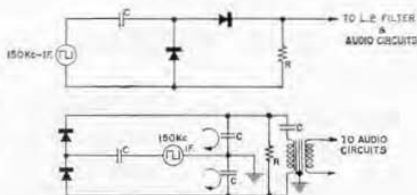

Figure 8. Discriminator used for f-m detection. At top, simple prototype; below, balanced circuit used in monitor.





filtering is necessary in the audio circuits that follow.

Precision Temperature-Controlled Crystal Oven

The heart of a frequency monitor is the quartz crystal employed to establish a reference frequency. The new unit developed specifically for this monitor is an example of simplicity in control.⁸

The circuit is shown in Figure 9. The main heater current is controlled by a small thyatron, which is turned on or off by a mercury-column thermostat. A cut-off, a-c, bias voltage is applied to the thyatron control-grid through the thermostat contacts, which close at 60° C. To prevent overshoot of the oven temperature, a small heater, or anticipator winding, is placed around the thermostat bulb.⁶

This control circuit is remarkably free from troubles due to contact resistances associated with the thermostat.

Figure 10 is a cross-section drawing of the crystal-oven detail. An outer aluminum cylinder surrounds the glass vacuum flask which has a balsa-wood plug at the open end. The heater is wound on a metal disc attached to this plug and all leads are brought out

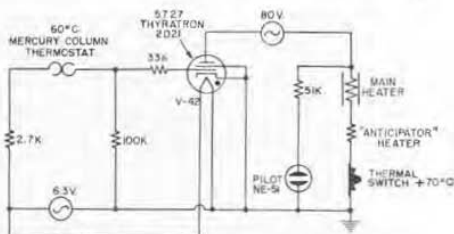

Figure 9. Schematic of control circuit for crystal oven.

through it. The heat loss by conduction along the wires is thus minimized, and a mechanical mount is made available for all internal parts. Included within the glass flask are the thermostat, quartz crystal mount, and two air-trimmer capacitors which are externally adjustable by means of insulated control rods.

The control characteristics of this oven are shown in Figure 11. In these tests, the ambient temperature was rapidly changed over a wide range, by means of rapid forced-air circulation. It represents an extreme condition not likely to be encountered in normal environments. For normal, slowly varying temperatures, the oven will maintain constant internal temperature at all times within a few hundredths of one degree C.

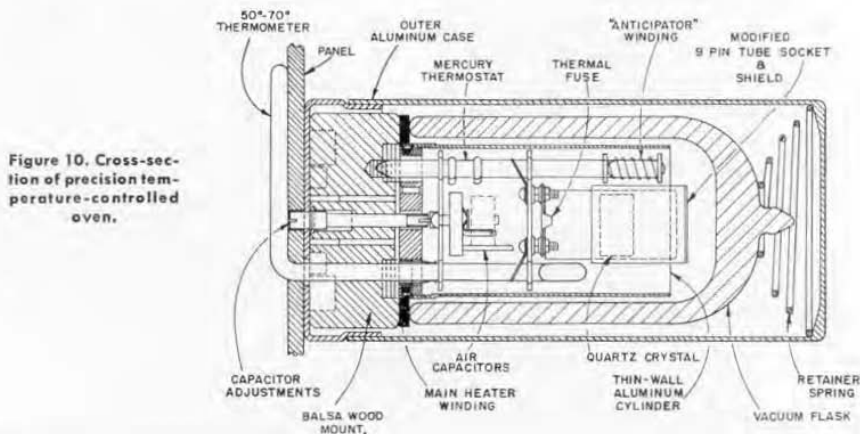

Figure 10. Cross-section of precision temperature-controlled oven.

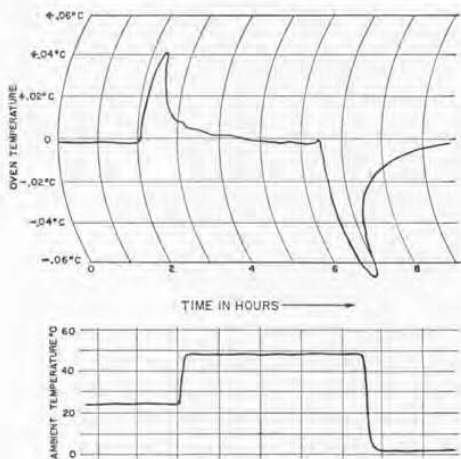

Figure 11. Control characteristics of the crystal oven.

A new AT-cut plated crystal is used, to provide the exceptional frequency stability necessary to meet the stringent requirements of u-h-f monitoring.

Power Supply

Particular consideration was given to the design of the power-supply section of this monitor. It is recognized that spare tube stocks are maintained, and replacements are always on hand. Metallic rectifiers may have longer life, but, when operated continuously, their ultimate replacement must be expected. Spare parts such as these are usually not immediately available and therefore become inconvenient to replace in this class of service.

As shown in Figure 12, two thyratrons are operated in a full-wave recti-

fier circuit. Control of the d-c output voltage is obtained by variation of the conduction time of each thyatron, through a d-c voltage applied to the thyatron grids. To improve the thyatron grid-control characteristics, a fixed a-c bias voltage is applied through two phase-shift networks. A conventional regulator circuit, as is commonly used with the series tube type of regulator, is used to develop the necessary d-c control voltage. A 5651 voltage-reference tube and a triode d-c amplifier are included.

In order that the ripple frequencies be isolated from the d-c regulator circuit, the ripple filter is placed between the transformer center tap and ground. Ripple frequency components are present only on the transformer secondary and are isolated by adequate transformer shielding.

General

Every effort has been made to reduce the effects of tube replacements, and to obtain normal operation throughout the entire life of the tubes. Special selection of tubes is unnecessary.

This monitor was designed with the assistance of Messrs. H. P. Hall and F. D. Lewis. Special credit is due Mr. W. F. Byers for his many valuable design contributions and to Mr. S. Samour for his untiring efforts in the making of experimental model and tests. Mr. H. G. Stirling was responsible for the design-drafting detail.

— C. A. CADY

Figure 12. Elementary schematic of regulated thyatron power supply.

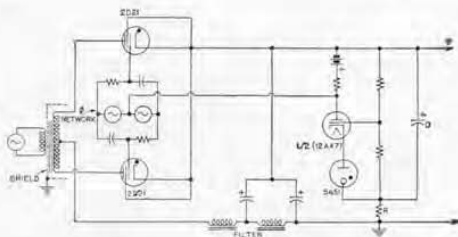



REFERENCES

1. FCC, Part 3, Radio Broadcast Services, Subpart E, Edition Effective January 2, 1956, pps. 3.687-3.690.
2. Cady, C. A., "Frequency and Modulation Monitor for TV and FM," TELETECH, February 1948, p. 44.
3. Cady, C. A., "Type 1170-A F-M Monitor for Broadcast and Television Services," GENERAL RADIO EXPERIMENTER, October 1947.
4. Lewis, F. D., "Ultra-High-Frequency Television Monitor," PROCEEDINGS OF THE NATIONAL ELECTRONICS CONFERENCE, 1951.
5. Cady, C. A., "FM Monitor Has Pulse-Counter Discriminator," FM AND TELEVISION, December 1947, p. 18.
6. CLAPP, J. K., "Notes on the Design of Temperature Control Units," GENERAL RADIO EXPERIMENTER, August 1944.
7. Cady, C. A., "A New Monitor for Television Transmitters," 1956 IRE CONVENTION RECORD, Part 7.
8. Cady, C. A., "A New Television Monitor," NARTB ENGINEERING CONFERENCE, April 1956. Reprint B-4 available from General Radio Company.

SPECIFICATIONS

Frequency Range: 50-890 Mc (tv channels 2 to 83).

RF Input:

1. Impedance: Low-impedance loop coupling.
2. Level: Intended for use with standard RETMA transmitter monitoring outputs (10 volts, 50 Ω).
3. Max Sensitivity: One volt, for all functions except the measurement of residual AM noise on the aural transmitter, which requires a minimum of 4 volts r-f input.
4. Adjustments: Input levels for both aural and visual transmitter are adjustable from the front of the instrument.
5. Indication: Both aural and visual transmitter input levels can be checked by direct indication on a front panel meter.

Frequency: Crystal Stability — master reference, ± 1.4 ppm/30 days or ± 0.35 ppm/10 days; secondary reference, ± 5 ppm/30 days (± 21.5 cycles) interpolating reference oscillator, ± 5 ppm/30 days (± 22.5 cycles).

Accuracy:

	Aural	Visual	Inter-Carrier
Meter Scale	3-0-3 ke	1.5-0-1.5 ke	3-0-3 ke
Metering Accuracy	$\pm 200c$	$\pm 30c$	$\pm 200c$
Overall Accuracy	VHF 500c/30 days UHF 500c/10 days		250c for 30 days

Image Frequency Check: A checking device is incorporated to insure that the transmitter frequency is on the correct side of zero beat.

Aural Modulation (FM): Meter Scale, 0 to 100% + 3 db, full scale; **Meter Ballistics,** as required by FCC specifications; **Meter Calibration,** 100% = 25 ke deviation; selector switch for 100% = 50 ke to permit wide-deviation type tests; **Polarity Response,** panel switch for positive or negative peaks, for both meter and flashing lamp; **Peak Indicator,** flashing lamp indicates peaks in excess of dial setting; **Dial,** calibrated from 0 to 100% and to +3 db above 100%; **Meter Frequency Response,** ± 0.25 db from 50 to

15,000 cycles, ± 0.5 db from 30 to 20,000 cycles; **Peak Indicator Frequency Response,** 0.5 db from 100 to 15,000 cycles.

Fidelity Measurements:

Aural F-M Transmitter: Audio Outputs (at low frequencies with 100% modulation), 10.8 volts into 100 k Ω or 0 dbm at 600 Ω . **Residual Distortion** (50 to 15,000 cycles), 0.15% for 25 ke modulation deviation, and 0.25% for 50 ke deviation; **Residual FM Noise,** -70 db below 25 ke modulation deviation; **Audio Response,** follows 75- μ sec de-emphasis curve within ± 0.5 db from 50 to 15,000 cycles, ± 3 db from 15 to 30 ke; **A-M Noise Reference Level** (at low frequencies), 4 volts into 100 k Ω ; **Residual Noise, AM,** -70 db below carrier level.

Visual A-M Transmitter: Noise (FM) Measuring Output (at low frequencies and 25 ke deviation), 1.5 volts into 100 k Ω load, 75- μ sec de-emphasis circuit included; **Residual (FM) Noise,** -65 db below 25 ke deviation with normal video modulation on transmitter (-70 db without video modulation).

Intercarrier Measurements: Same as for aural transmitter, except **Residual (FM) Noise** is -63 db below 25 ke deviation of aural transmitter with video modulation applied to visual transmitters.

External Connections:

1. **Frequency Meters:**
Visual Transmitter, GR TYPE MEDS-41-3, 0-200 μ a dc, 510 Ω , one side grounded.
Aural Transmitter, GR TYPE MEDS-72, 0-100 μ a dc, 510 Ω , one side grounded.
2. **(FM) Modulation Meter:** GR TYPE MEDS-28, 0-600 μ a dc, 680 Ω , neither side grounded.
3. **Modulation-Peak Indicator:** 3 watt-115 v lamp, one side grounded.
4. **Audio Monitoring Output:** Unbalanced — 600 Ω , 100% modulation = 0 dbm.
5. **Audio Measurement Output:** Intended for use with the TYPE 1932-A Distortion and Noise Meter (100 k Ω unbalanced input); 10.8 volts output at low frequencies; behind-the-panel test jack for connecting on a temporary basis;





rear jack provided for permanent wiring to rack-mounted Distortion and Noise Meter.

6. *Power Cables:* standby line, for master crystal oven; power line, for monitor circuits.

Power Supply:

1. Standby Operation:
15 watts, with master crystal oven operating.
115/230 volts; 50-60 cycles.
2. Normal Operation:
Max demand 265 watts, with all thermostats on.
Min demand 240 watts, with all thermostats off.

Type

1184-A

Television Transmitter Monitor

Code Word

GIANT

Price

\$2650.00

U. S. Patents Nos. 2,548,457 and 2,362,503. Licensed under patents of the American Telephone and Telegraph Company, patents of the Radio Corporation of America;

115/230 volts; 50-60 cycles.

(155 watts during 30 second initial warm up).

Mounting: 19-inch rack-panel mounting. Front panel removable for access to controls. All controls available from front. Instrument mounted on slides for access to all parts. Designed for vertical-air-flow cabinet racks.

Panel Finish: GR black crackle; also available in certain other colors to match station equipment.

Dimensions: (Width) 19 x (height) 21 x (depth) 16 inches, over-all.

Net Weight: 75 lbs.

and patents and patent applications of G. W. Pierce pertaining to piezo-electric crystals and their associated circuits.

THE NEW TYPE 1800-B VACUUM-TUBE VOLT-METER - STABLE AND ACCURATE

The TYPE 1800-B is a precision Vacuum Tube Voltmeter designed for a wide range of applications. It combines the accuracy of a laboratory instrument with the durability necessary for everyday laboratory and production-line use.

Its accuracy is better than $\pm 2\%$ on all a-c and d-c voltage ranges, and its

completely shielded diode probe is designed for use into the u-h-f range. The design and construction of this instrument insures that the high accuracy of the new voltmeter will be sustained throughout years of service. This important stability has been achieved through three means: advanced circuit design, thorough power supply regulation, and the use of long-term-stable precision components.

Each increasingly higher voltage range is obtained by an increase in degeneration that decreases the sensitivity of the d-c amplifier, rather than by use of the conventional voltage divider to feed a constant-gain amplifier. As a result, the circuit is substantially independent of drift in tube transconductance on all but the 1.5- and 0.5-volt ranges, and even there a simple adjust-



Figure 1. View of the Type 1800-B Vacuum-Tube Voltmeter. It is similar in appearance to its predecessor, the Type 1800-A, but includes a panel switch for d-c polarity selection.





ment compensates for tube drift. On a-c ranges maximum stability is insured through the use of an internal balancing diode, a feature not often found in voltmeters, but which is essential to first-class performance. These refinements in circuit design coupled with thorough, two-stage power supply regulation, make the meter independent of line-voltage fluctuations. Once the zero is set on the 0.5-volt range, no further adjustment is required for this or any other range. The use of precision wire-wound resistors insures that the accuracy of the instrument will be maintained indefinitely.

The TYPE 1800-B is an extremely versatile test instrument. In addition to performing reliably all the normal routine voltage measurements, many features not found in other instruments have been included to make this vacuum-tube voltmeter suitable for tackling especially difficult measurements. The following list of features highlights the remarkable versatility of the TYPE 1800-B:

1. Excellent high-frequency range through use of a convenient diode probe. VHF voltages may be accurately measured *without* need of special grounding devices, probe disassembly, or external capacitors.

2. Completely shielded probe affords normal accuracy even in the presence of strong r-f fields.

3. Thoroughly shielded amplifier circuit and well-filtered probe eliminate any possibility of "beats" in the measurement of voltages at frequencies near power-line frequency or its harmonics.

4. The probe cap may be simply bolted to the ground plane of the test circuit, eliminating the possibility of error through ground lead inductance and pickup from electromagnetic fields.

5. The probe may be conveniently

plugged into standard 3/4-inch jack-top binding posts, and additional a-c terminals are provided on the panel so that test leads may be used rather than the probe, if so desired.

6. A storage space is provided for the probe under a hinged cover at the top of the instrument.

7. A TYPE 874 coaxial fitting and 50-ohm termination are provided. These permit the probe to be used on coaxial lines.

8. High input impedance — resistive component 25 megohms at low frequencies. Open grid connection available for de provides input impedances in the kilo-megohm range.

9. Panel can be grounded without grounding any of the input terminals. This is an important safety feature; it allows a-c or d-c voltages to be measured between two points, both above d-c ground, without the panel becoming "hot".

10. A polarity switch is provided for d-c measurements. This switch permits either positive or negative voltages to be read without the need of reversing the test leads.

11. An illuminated meter scale eliminates reading difficulties caused by light reflection from the meter glass.

12. The meter's knife edge pointer and mirror insure ease and precision of reading.

13. The carrying handle detents into a right angle position so that the instrument panel may be supported at the most convenient angle for easy reading.

The features outlined above are a few of the items specifically engineered into the TYPE 1800-B to make it the most convenient and useful Vacuum-Tube Voltmeter on the market. The specifications shown below detail the performance of this instrument.

— C. A. WOODWARD, JR.



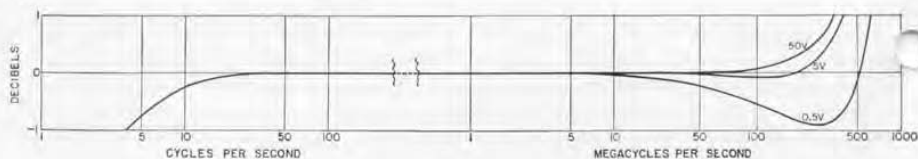

Figure 2. Plot of frequency range for one-db error on three voltage ranges as indicated; error is result of combined transit-time and resonance effects.

SPECIFICATIONS

Voltage Range: 0.1 to 150 volts, ac, in six ranges (0.5, 1.5, 5, 15, 50, and 150 volts, full scale); 0.01 to 150 volts, dc, in six ranges (0.5, 1.5, 5, 15, 50, and 150 volts, full scale).

Multipliers: Multipliers are available for increasing the range to 1500 volts.

Accuracy: DC, $\pm 2\%$ of full scale; AC, $\pm 2\%$ of full scale for sinusoidal voltages, subject to frequency correction (see curve). Because of the change in resistance of the meter movement, the sensitivity of the lowest two ranges changes slightly with temperature and upon warming up of the instrument. The total warm-up decrease in sensitivity is about 1% of the indicated value on the 1.5-volt range and 3 to 4% of the indicated value on the 0.5-volt range. About one-half of this drift occurs in the first hour. The calibration is set to be correct after complete warm-up.

Waveform Error: On the higher a-c voltage ranges, the instrument operates as a peak voltmeter, calibrated to read r-m-s values of a sine wave, or 0.707 of the peak value of a complex wave. On distorted waveforms the percentage deviation of the reading from the r-m-s value may be as large as the percentage of harmonics present. On the lowest range the instrument approaches r-m-s operation.

Frequency Error: At high frequencies, resonance in the input circuit and transit-time effects in the diode rectifier introduce errors in the meter reading. The resonance effect causes the meter to read high and is independent of the applied voltage. The transit-time error is a function of the applied voltage and causes the meter to read low. The curves of Figure 2 show the frequency range for 1-db resultant error. It will be noted that at low voltages the transit-time and resonance effects tend to cancel, while at higher voltages the error is almost en-

tirely due to resonance. The resonant frequency with cap on but plug removed is about 1050 Mc. Correction curves are supplied.

At a frequency of about 15 cycles, the meter indication begins to fluctuate as it tends to follow the voltage change within each cycle.

Input Impedance: At low frequencies the equivalent parallel resistance of the a-c input circuit is 25 megohms. At higher frequencies this resistance is reduced by losses in the shunt capacitance. The equivalent parallel capacitance at radio frequencies is 3.1 μf with the probe cap and plug removed. At audio frequencies this capacitance increases slightly. The probe cap and plug add approximately 1.2 μf .

On the d-c ranges two values of input resistance are provided, 10 megohms and open grid.

Power Supply: 105 to 125 or (210 to 250) volts, ac, 50 to 60 cycles. The instrument incorporates a voltage regulator to compensate for supply variations over this voltage range. The power input is less than 25 watts.

Tube Complement:

2-9005	1-6SL7-GT
1-6SU7-GTY	1-6AT6
1-6C4	1-6X5-GT
1-3-4	2-991

Accessories Supplied: TYPE CAP-35 Power Cord, spare fuses, TYPE 274 and TYPE 874 terminations, and 50-ohm coaxial terminating resistor for probe.

Mounting: Black-crackle-finish aluminum panel mounted in a shielded walnut cabinet. The cable and probe are stored in the cabinet. The carrying handle can be set as a convenient support for the instrument when placed on a bench with the panel tilted back.

Dimensions: (Width) $7\frac{1}{8}$ x (depth) $7\frac{1}{2}$ x (height) $11\frac{1}{8}$ inches, over-all. **Net Weight:** $13\frac{3}{4}$ pounds.

Type

Code Word

Price

1800-B

Vacuum-Tube Voltmeter.....

DUCAT

\$415.00

U. S. Patent No. 2,548,457. Licensed under patents of the Radio Corporation of America.

GENERAL RADIO COMPANY

275 MASSACHUSETTS AVENUE

CAMBRIDGE 39

MASSACHUSETTS

TELEPHONE: Trowbridge 6-4400

PRINTED
IN
U.S.A.



IET LABS, INC in the GenRad tradition

534 Main Street, Westbury, NY 11590

www.ietlabs.com

TEL: (516) 334-5959 • (800) 899-8438 • FAX: (516) 334-5988