

the GENERAL RADIO Experimenter



1957 • GENERAL RADIO Company, Cambridge, Mass., U.S.A.
Since 1915 — Manufacturers of Electronic Apparatus for Science and Industry

VOLUME 31 No. 11

APRIL, 1957



Photo Courtesy Ohio State University

In This Issue

New 50-Ampere Variac
Sound-Survey Meter as Transfer Standard
Double-Pulse Generation



IET LABS, INC in the GenRad tradition
534 Main Street, Westbury, NY 11590

www.ietlabs.com
TEL: (516) 334-5959 • (800) 899-8438 • FAX: (516) 334-5988



THE GENERAL RADIO EXPERIMENTER

Published Monthly by the General Radio Company

VOLUME 31 • NUMBER 11

APRIL, 1957

CONTENTS

	Page
New "50" Size VARIACS®	3
The Sound-Survey Meter as a Transfer Standard	9
Double Pulses with the Type 1391-A Pulse, Sweep, and Time-Delay Generator	10
Coming Shows	12

COVER



Radio astronomy is rapidly opening up new vistas of the universe which are not visible with optical instruments. The cover photograph shows the 96-element helical antenna of the radio telescope at Ohio State University. It operates 24 hours per day, mapping the sky on a moving paper chart.

The inset shows Donn Van Stoutenburg, a graduate student at OSU, using the General Radio Type 1602-B UHF Admittance Meter for matching the antenna input circuits of the radio telescope at 242 megacycles. The speed of measurement provided by the Admittance Meter is an important factor in design and maintenance.

These photographs are reproduced through the courtesy of Dr. John D. Kraus, Professor of Electrical Engineering, and Director of the Radio Observatory.

The General Radio EXPERIMENTER is mailed without charge each month to engineers, scientists, technicians, and others interested in electronic techniques in measurement. When sending requests for subscriptions and address-change notices, please supply the following information: name, company address, type of business company is engaged in, and title or position of individual.

GENERAL RADIO COMPANY

275 Massachusetts Avenue

Cambridge 39

Massachusetts

Telephone: TRowbridge 6-4400

BRANCH ENGINEERING OFFICES

NEW YORK: Broad Avenue at Linden, Ridgefield, New Jersey
Telephone—N. Y., WOrth 4-2722
N. J., WHitney 3-3140

CHICAGO: 920 South Michigan Ave., Chicago 5, Illinois
Telephone—WAbosh 2-3820

PHILADELPHIA: 1150 York Road, Abington, Pennsylvania
Telephone—HAncock 4-7419

WASHINGTON: 8055 13th St., Silver Spring, Maryland
Telephone—JUniper 5-1088

LOS ANGELES: 1000 North Seward St., Los Angeles 38, Calif.
Telephone—HOLlywood 9-6201

SAN FRANCISCO: 1182 Los Altos Ave., Los Altos, Calif.
Telephone—WHitecliff 8-8233

REPAIR SERVICES

WEST COAST: Western Instrument Co., 826 North Victory
Boulevard, Burbank, Calif.
Telephone—VICTORIA 9-3013

CANADA: Bayly Engineering, Ltd., First St., Ajax, Ontario
Telephone—Toronto EMpire 8-6866



IET LABS, INC in the GenRad tradition

534 Main Street, Westbury, NY 11590

TEL: (516) 334-5959 • (800) 899-8438 • FAX: (516) 334-5988

www.ietlabs.com



NEW "50" SIZE VARIACS[®] —TYPES W50 AND W50H



Figure 1. The new Type W50, largest of the Variacs, shown with the smallest standard unit, Type W2.

The old, reliable work horses of the continuously adjustable, high-power autotransformer field, TYPES 50A and 50B Variacs[®], are being retired to a well-earned rest after many years of faithful and satisfactory service. To supplant these deservedly popular models, General Radio now introduces the new TYPES W50 and W50H. Embodying the many advantages inherent in the "W" design¹, these new "50's" deliver more watts per dollar, with smaller size, less weight, and lower losses than their predecessors. Mounting hole dimensions and arrangement are unchanged, for maximum interchangeability.

Current ratings are increased. The rated currents for the new 115-volt and 230-volt models are, respectively, 50 and 25 amperes, as contrasted to 40 and 20 amperes for the old models. TYPES W50 and W50H are UL-approved; cased models are undergoing examination and test for listing.

The general scheme of construction follows that of the W-type Variacs previously announced.¹ The radiator

is captive, so that shaft adjustments do not upset radiator and brush setting. The base is stamped from plate stock, thus possessing superior physical properties to cast or die-cast construction. The assembly is secured by a hollow bolt, which serves as a shaft sleeve or ball-bearing housing as requirements dictate.

Because of the massive core and winding structure, the base insulator is molded and serves to lock the coil relative to the base under severe shock conditions. The coil is cemented to this molded insulator with a thermo-setting plastic to improve mechanical stability and thermal transfer from coil to base. Coil forms are the angel-cake-pan type previously described, which completely enclose the core.

Unique with these units is the use of a banked winding for such heavy wire; the process might be more properly described as "rod-bending" rather than

¹"The Type W5 Variac — A New and Better Variable Autotransformer," *General Radio Experimenter*, December, 1955, XXX, 7, pp. 1-11.
"More New Variacs," *General Radio Experimenter*, May, 1956, XXX, 12, pp. 13-15.





Figure 2. The Type W50M, cased model, shown in a typical wall installation with conduit wiring.

as "winding!" The winding machine was designed and built by General Radio. It actually oscillates the core during winding to force banking of the heavy conductors, and an ingenious servo-mechanism keeps the core rotation in step with the winding gear regardless of slippage in the belt drive.

The use of multiple brushes, consequent upon the high current rating, posed a dimensional problem — how to accommodate the wide, single-layer brush track, without an excessive core diameter, on a bank wound unit. This was solved by placing the brush track on the outer face of the toroid. (Figure 3). This brush location allows the closest approach to an ideal core aspect ratio for a given number of turns of the required wire size in a banked winding, for a minimum required panel space. A copper radiator "nose" serves to conduct both brush heat and brush

current to the radiator, which is painted black on the surface away from the Variac for maximum radiant heat dissipation. The new unit brush, first introduced on the TYPE M20 Variac,² is used on the W50's, the better to carry away the heat generated by these higher powered units.

The *Duratrak* brush track is, of course, used on the new Type W50 and TYPE W50H. This has not been available on the older 50A and 50B types, and it brings a new degree of reliability to Variacs in the high-power field, a reliability approaching that of fixed-ratio power transformers.

Stud terminals and screw-type pressure connectors on the W50 provide maximum convenience for a variety of conductor sizes and circuits. Screw terminals similar to those used on the M20² are provided on the W50H. The terminal arrangement is the same as that on the standard W-model Variacs.

A built-in protector prevents damage to the costly winding from *sustained* overloads exceeding 160% of rating.

Adequate fuse or breaker protection should be provided in any installation of these Variacs to open the brush circuit on currents appreciably in excess of the rating. The added margin of safety afforded by the built-in protector

² "A 400-Cycle Variac with 20-Ampere Rating," *General Radio Experimenter*, 31, 8; January, 1957; pp. 7-8.

Figure 3. Close-up of the banked winding and *Duratrak* commutator surface.



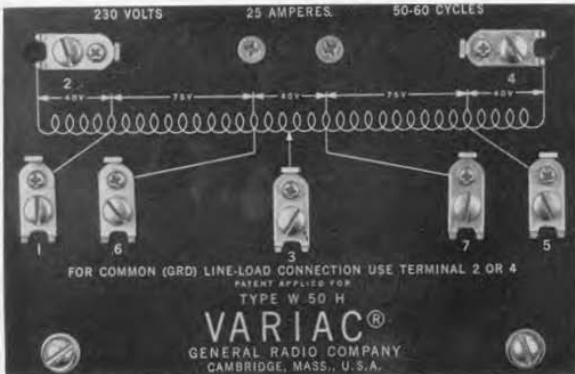

Figure 4. Terminal plate for the Type W50H, 230-volt model. The 115-volt model with higher current rating uses stud terminals and screw-type pressure connectors.



Figure 5. Close-up of the brush assembly and connectors.

SINGLE UNITS

Type	Mounting	Input (50-60 Vols (cycles))	Line-Voltage Connection				Overvoltage Connection		Net Weight—Pounds	Code Word	Price
			Rated Output Amperes	Output Vols	Max. Output Amperes	Output KVA	Output Vols	Rated Output Amperes			
W50	Without case	115	50	0-115	50	5.75	0-135	50	GATAL	\$120.00	
W50M	Cased	115	40	0-115	45	5.18	0-135	40	GATER	145.00	
W50H	Without case	230	25	0-230	32.5	7.5	0-270	25	NITAL	120.00	
W50HM	Cased	230 115	20	0-230	31	7.13	0-270 0-270	20 10	NITER	145.00	
VBT-6	Replacement brush set for W50, W50M								1/4		5.00
VBT-7	Replacement brush set for W50H, W50HM								1/4		5.00

is available when, through negligence or accident, normal protective devices are not operating.

The TYPE W50 and TYPE W50H, as with other W-model Variacs, are available singly or in gangs, for manual or motor-driven operation, open or cased, with or without ball bearings.

We feel that the TYPE W50 and TYPE W50H Variacs with their increased output, lowered cost, weight, size, and losses will prove to be worthy successors to the TYPES 50A and 50B that they replace.

Figure 6. Cover of the M-type unit is easily removable.

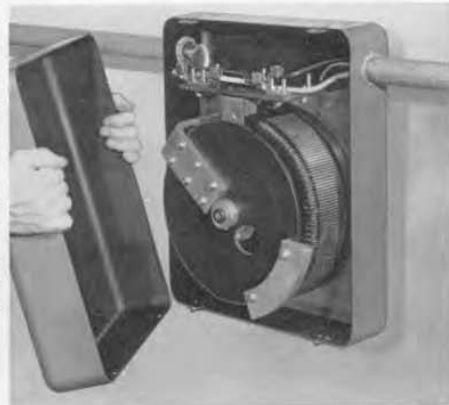

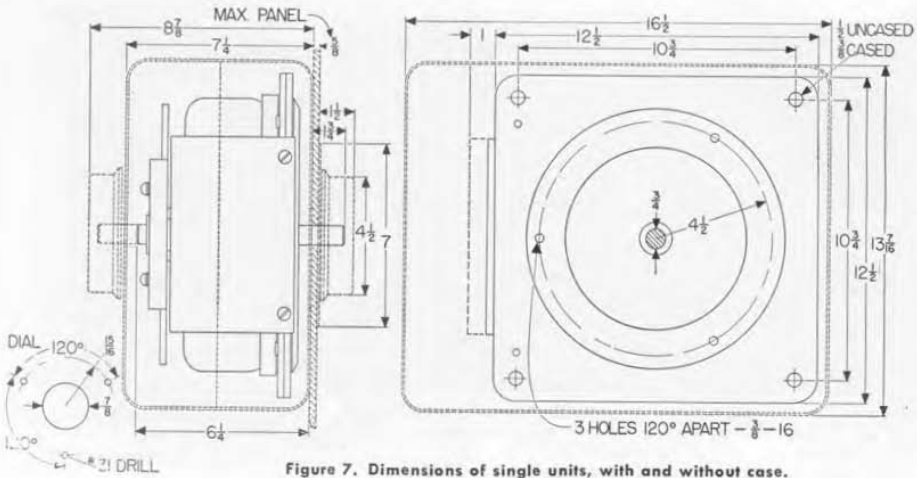

Figure 7. Dimensions of single units, with and without case.

SPECIFICATIONS

Core Loss at 60 cycles, all models:	50 watts
Driving Torque, all models:	200-400 oz.-in.
Turns on Winding:	
W50, W50M	190
W50H, W50HM	298
Angle of Rotation:	320°

D-C Resistance of Winding:

W50, W50M 0.075 ohm

W50H, W50HM 0.3 ohm

Dial Calibration: Reversible dial, line-voltage scale on one side, overvoltage on reverse side; accurate with rated input voltage applied.

GANGED UNITS

Ganged assemblies of TYPE W50 Variacs are used in parallel or in series on single-phase lines and in open delta or wye configurations on three-phase lines. The table on page 7 indicates the

ratings of the various combinations. Dial plates for gangs have scales marked 0-10. TYPES 50P1 and 50P2 chokes to limit circulating currents are recommended for parallel operation.

Figure 8. (below) Two-gang assembly.
(right) Three-gang assembly with case.

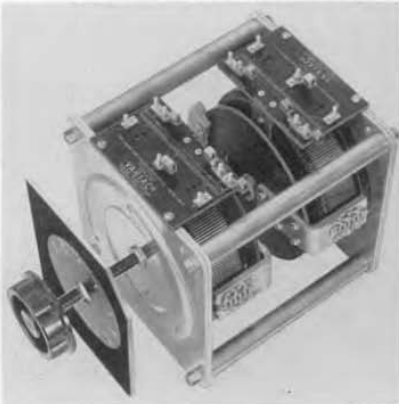



RATINGS FOR GANGED UNITS

SINGLE PHASE CIRCUITS

Type	Input Volts	Output Volts	Max. Output Amperes	Rated Output Amperes	Output KVA†	Connection	Chokes Required
W50G2	115	0-115 0-135	100	100 100	11.5	Parallel	One Type 50-P1
W50G2M	115	0-115 0-135	90	80 80	10.4	Parallel	One Type 50-P1
W50G3	115	0-115 0-135	150	150 150	17.25	Parallel	One Type 50-P1 One Type 50-P2
W50G3M	115	0-115 0-135	135	120 120	15.5	Parallel	One Type 50-P1 One Type 50-P2
W50HG2	230	0-230 0-270	65	50 50	15	Parallel	One Type 50-P1
W50HG2M	230	0-230 0-270	62	40 40	14.3	Parallel	One Type 50-P1
W50HG3	230	0-230 0-270	97.5	75 75	22.5	Parallel	One Type 50-P1 One Type 50-P2
W50HG3M	230	0-230 0-270	93	60 60	21.4	Parallel	One Type 50-P1 One Type 50-P2
W50HG2	460	0-460 0-540	32.5	25 25	15	Series *	
W50HG2M	460	0-460 0-540	31	20 20	14.3	Series *	
THREE-PHASE CIRCUITS							
W50G2	115	0-115	50	50	10	Open	
W50G2M	115	0-115	45	40	9	Delta	
W50G3	230	0-230	50	50	20	Wye	
W50G3M	230	0-230	45	40	18	Wye	
W50HG2	230	0-230	32.5	25	13	Open	
W50HG2M	230	0-230	31	20	12.3	Delta	
W50HG3	460	0-460	32.5	25	26	Wye	
W50HG3M	460	0-460	31	20	24.6	Wye	

* Does not permit common connection between line and load. Load must not be grounded.

† No KVA rating is given for overvoltage connection. Output KVA is determined by the product of line voltage and maximum current for the line-voltage connection.

Type	Description	Net Weight Pounds	Code Word	Price
W50G2	Two-Gang W50, without case	103	GATALGANDU	\$260.00
W50G2M	Two-Gang W50, with case	115½	GATALBONDU	310.00
W50G3	Three-Gang W50 without case	158	GATALGANTY	385.00
W50G3M	Three-Gang W50 with case	173½	GATALBONTY	440.00
W50HG2	Two-Gang W50H, without case	109	NITALGANDU	260.00
W50HG2M	Two-Gang W50H, with case	121½	NITALBONDU	310.00
W50HG3	Three-Gang W50H, without case	167	NITALGANTY	385.00
W50HG3M	Three-Gang W50H, with case	182½	NITALBONTY	440.00

Dial plates on ganged units read 0 to 10
Driving torque: Two-gang, 400-800 oz.-in.
Three-gang, 600-1200 oz. in.

CHOKES

Type	Description	Code Word	Price
50-P1	For operation of two units in parallel	PARALLCHOK	\$14.00
50-P2	Used with 50-P1 for operation of three units in parallel	TRIPLECHOK	14.00





BALL BEARINGS

Every TYPE W50 Variac assembly (single or ganged) can be furnished with ball bearings, which reduce the required driving torque. Surcharge for ball bearings:

Single Unit.....	\$15.00
2-Gang.....	20.00
3-Gang.....	25.00

When ordering, add suffix BB to type number.

MOTOR DRIVE

Motor drives are available for TYPE W50 Variacs, as shown in the table on page 9. All models include motor capaci-

tor and adjustable-position micro-switches to limit the arc of traverse to any desired portion of the winding. All

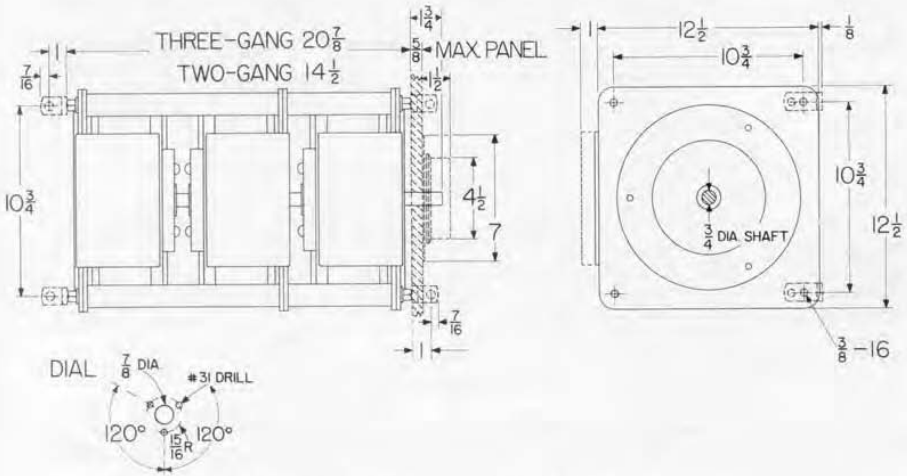

Figure 9. Dimensions of ganged assemblies, without case.

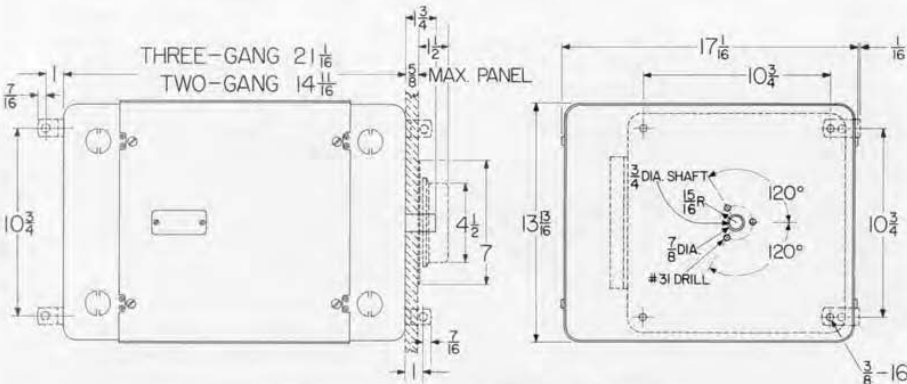

Figure 10. Dimensions of ganged assemblies, with case.





motor-driven models are equipped with ball bearings.³ Type numbers are made up on the following basis, as explained in a previous article.⁴

—GILBERT SMILEY

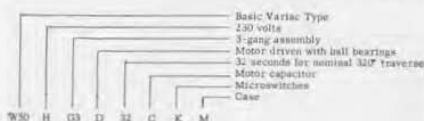

PRICES*

VARIAC Type	TRAVERSE TIME IN SECONDS				Add for case
	16	32	64	128	
W50	\$260.00	260.00	260.00	260.00	\$55.00
W50G2		390.00	390.00	390.00	60.00
W50G3		520.00	520.00	520.00	65.00
W50H	260.00	260.00	260.00	260.00	55.00
W50HG2		390.00	390.00	390.00	60.00
W50HG3		520.00	520.00	520.00	65.00

* In lots of 5 or more. For quantities less than 5, there is a setup charge of \$12.00, prorated over the number of units. (1-4).



Figure 11. View of motor-driven unit, without case; Type W50D16CK.

³ It is not necessary to add BB to the type number when the Variac is ordered with motor drive.

⁴ "Motor Drives for W-Series Variacs", *General Radio Experimenter*, 31, 3; August, 1956, pp. 1-4.

THE SOUND-SURVEY METER AS A TRANSFER STANDARD

To assure uniformity and compliance with sensitivity specifications, hearing aids are given an over-all acoustical check. At Otarion, Inc., of Dobbs Ferry, New York, manufacturers of hearing aids, these devices are tested by standard methods using an artificial voice and an artificial ear.

The test stand shown in Figure 1 is an example of this technique as used to test the Listener[®] hearing aid, which is an eyeglass type and the first such unit to be produced commercially. The artificial voice, which consists of a small speaker in a box lined with sound-absorbing material, is shown at

the top, with the bow containing the microphone of the hearing aid inserted through the opening and resting in the test position. The receiver, which is in the other eyeglass bow, is coupled acoustically by means of a small transparent tube, to a standard 2-cc cavity.

In this apparatus, the sound-pressure in the box is calibrated originally against the laboratory standard, a Kellogg condenser microphone. Since the calibration equipment is cumbersome, and also because it is desirable to avoid excessive use of the standard microphone, the General Radio Sound-Survey Meter is used as a transfer





Figure 1. Test stand for the Listener[®] hearing aid.

standard. An opening at the base of the artificial voice makes possible the insertion of either the Sound-Survey Meter or the standard condenser microphone to measure the sound-pressure level. As shown in Figure 2, this procedure involves no cumbersome equipment and can be accomplished quickly and easily. Thus periodic checks with this simple and convenient device will indicate immediately any change in level that has occurred in the interval



Figure 2. Sound-Survey Meter in position to measure sound level.

between calibrations with the laboratory standard and also any differences that may exist between various test positions.

Otarion, Inc., also finds the Sound-Survey Meter useful for routine checks of audiometer calibration.

We are indebted to Mr. William H. Greenbaum, Vice President and Director of Engineering at Otariion, Inc., for the information in the above article.

DOUBLE PULSES WITH THE TYPE 1391-A PULSE, SWEEP, AND TIME DELAY GENERATOR

Many inquiries have prompted investigation of methods of producing double pulses with the TYPE 1391-A Pulse, Sweep, and Time-Delay Generator. This article will present two possible methods. In the first method, each pulse of the pair has the same duration, and the interval between pulses is set by the delay controls. In the second method, durations of the first and second pulses and the inter-

pulse interval are all independently variable.

In the first method, two sweeps and their associated pulses are produced, the first timed by the direct synchronizing pulse, and the second by the delayed synchronizing pulse. Thus, basically, the inter-pulse interval is the DELAY setting (1 μ sec to 1 sec), and the duration of each pulse of the pair is that indicated by the setting of the PULSE



DURATION control (see Figure 1). Since the minimum sweep duration is $3 \mu\text{sec}$, and 1-to-2 μsec recovery time should be allowed, the actual minimum pulse delay is 4 to 5 microseconds. Note also that the pulse-delay interval produces and registers a delay between the direct synchronizing pulse and the first pulse of the pair. This procedure, according to the instrument specifications and the comments of this paragraph, yield the following possible ranges: duration of each pulse of pair, $0.05 \mu\text{sec}$ to 0.1 sec ; interpulse interval, $5 \mu\text{sec}$ to 1 sec ; delay from direct synchronizing pulse to first pulse of pair, $0.25 \mu\text{sec}$ to 0.1 sec .

This double pulse is obtained by connection of the DIRECT SYNC post to the POS. COINCIDENCE DRIVE post through a 3.3 kilohm resistor. The direct synchronizing pulse is large enough to produce an output from the delay synchronizing circuits under these circumstances, and, with the SWEEP TRIGGER switch in DELAYED position, the two sweeps of Figure 1 are produced.

The second method will produce a pulse pair of completely independent duration and interpulse interval. The time relationships are shown in Figure 2. The duration of the first pulse is that set by the DELAY control. The interval between pulses is that set by the PULSE DELAY control, and the duration of the second pulse is that set by the PULSE DURATION control. Thus we have, from the catalog specifications for the instrument under the following figures:

- (1) First pulse duration, $1 \mu\text{sec}$ to 1 sec .
 - (2) Interpulse delay, $0.25 \mu\text{sec}$ to 0.1 sec .
 - (3) Second pulse duration, $0.05 \mu\text{sec}$ to 0.1 sec .
- (Note that at maximum sweep duration, interpulse delay and pulse duration must be traded. If a 0.05-sec. pulse

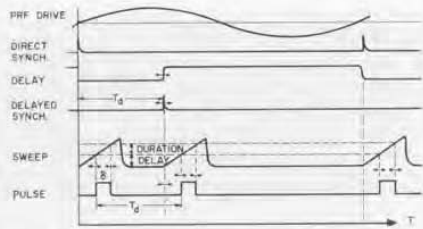

Figure 1. First Method. Equal pulse duration, adjustable time interval.

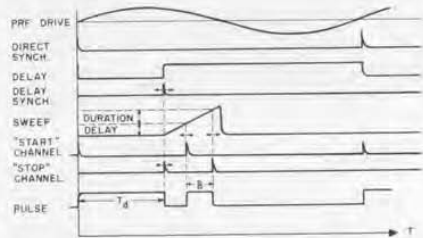
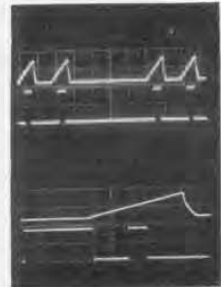

Figure 2. Second Method. Delay circuits set first pulse duration; sweep sets inter-pulse delay and second pulse duration.

is desired, only 0.05 second delay is available, etc.)

No internal modification of the instrument is needed to produce this double pulse. The direct and delayed synchronizing pulses are used to start and stop the first pulse, while the sweep,

Figure 3a.
Double Pulse
First Method
12- μsec sweep
25- μsec delay
8- μsec pulse
PRF—10 kc



Double Pulse
Second Method
12- μsec sweep
1st pulse 10 μsec
Delay 5 μsec
2nd pulse 2.5 μsec

Figure 3b.
Showing minimum duration of push-pull output pulses and interpulse delay; method 2.



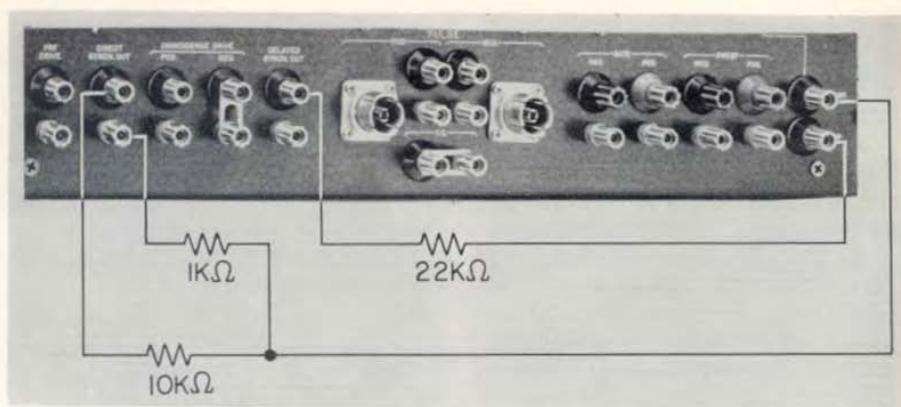

Figure 4. Network and connections for producing a double pulse by the second method.

started with the SWEEP TRIGGER switch in the DELAYED position, produces interpulse delay and times the second pulse. The circuit which superimposes the direct and delayed synchronizing pulses on the internally produced start and stop pulses is shown in Figure 4. These networks are connected between the DIRECT SYNC and START, and the

DELAYED SYNC and STOP, binding posts. Then the SWEEP START toggle switch is set to DELAYED and the PULSE SOURCE DRIVING FUNCTION switch is set *midway* between the INTERNAL and EXTERNAL positions. This switch will permit the internally produced timing pulses and the externally produced pulses to be added together.

— R. W. FRANK

COMING SHOWS

In the month of May, General Radio equipment will be on display at three technical apparatus shows. We hope to see you at the General Radio booth.

SEVENTH ANNUAL RESEARCH EQUIPMENT EXHIBIT AND APPARATUS SYMPOSIUM

National Institutes of Health Bethesda, Maryland Booth 80 May 13-16, 1957

NATIONAL CONFERENCE ON AERONAUTICAL ELECTRONICS

Dayton Billmore Hotel Dayton, Ohio Booths 28 and 29 May 13-15, 1957

ACOUSTICAL SOCIETY OF AMERICA

Barbizon Plaza Hotel New York Booth 2 May 23-25, 1957



General Radio Company

PRINTED
IN
U.S.A.



IET LABS, INC in the GenRad tradition

534 Main Street, Westbury, NY 11590

TEL: (516) 334-5959 • (800) 899-8438 • FAX: (516) 334-5988

www.ietlabs.com